



เครื่องปรับอากาศ “แคเรียร์”



40RR Series

Packaged Air Handling Unit

Nominal: 10-30 Tons



40RR Series



These fan coil units offer customized arrangement with Carrier's renown dependability.

The **40RR** air handlers provide an efficient source of conditioned air for factories, shops, offices or restaurants. Coupled with appropriate condensing unit, the **40RR Series** produce nominal capacities from 120,000 to 400,000 btu/hr.

Slim proportions (less than 910 mm. deep) allow these units to be floor-mounted or ceiling-suspended. Modular construction allow interchangeable fan section arrangement to select optimum air discharge.

Compatible with



38AE Series

Air-cooled condensing units having nominal capacities 120,000 to 400,000 btu/hr. Inside and outside surface ensure long life, excellent finish and corrosion resistance.

Features

- Semi-hermetic reciprocating compressor
- Compact size
- Reliable operation



38LB Series

Air-cooled condensing units designed for easy installation and service. Its come in 5 size 5 covering range of capacities.

Features

- Fully hermetic Scroll compressor
- Flexible air discharge configuration
- Reliable operation

Physical data

Description			Packaged Air Handling Unit					
Model			40RR010	40RR015	40RR020	40RR025	40RR030	40RR040
Nominal Capacity		BTU/Hr (KW)	120,000 (35)	150,000 (44)	200,000 (58)	280,000 (82)	310,000 (90)	388,000 (113)
Operating Weight		lb (kg.)	366 (166)	472 (214)	622 (282)	670 (304)	1114 (505)	1158 (525)
Air Quantity	Range	CFM	2,000-3,400	3,200-5,400	4,400-7,500	5,200-8,600	6,500-10,700	7,800-13,000
	Nominal	CFM	3,300	5,300	6,600	8,000	8,600	10,300
Cooling Coil	Rows...Fins/sq.in.		4...14	3...14	3...14	4...14	4...14	4...14
	Total Face Area	sq. ft.	6.76	10.78	14.88	17.22	21.50	26.04
	Upper Coil	sq. ft.	3.38	5.39	7.44	8.84	10.75	13.02
	Lower Coil	sq. ft.	3.38	5.39	7.44	8.38	10.75	13.02
Expansion Valve	Upper Coil		TCLE5HW	TCLE5HW	TCLE7.5HW	TCLE10HW	TCLE12HW	TCLE15HW
	Lower Coil		TCLE5HW	TCLE5HW	TCLE7.5HW	TCLE10HW	TCLE12HW	TCLE15HW
Fan	Fan No...Dia.	in.	2...10	2...12	2...15	2...15	2...18	2...18
	Shaft Dia.	in.	1.0 (25)	1.2 (30)	1.2 (30)	1.2 (30)	1.4 (35)	1.4 (35)
	Speed Range	rpm	600-1,900	500-1,500	400-1,200	400-1,200	300-1,000	300-1,000
	Standard Speed	rpm	875	875	839	845	766	766
	Standard Fan Pulley		200-1B-25	200-1B-30	225-1B-30	225-1B-30	250-2B-35	250-2B-35
	Standard Motor Pulley		125-1B-24	125-1B-28	132-1B-28	132-1B-28	132-2B-38	132-2B-38
	Standard Belt...Qty.		B-46...1	B-49...1	B-39...1	B-39...1	B-66...2	B-66...2
Fan Motor	Range	Hp.	1-2	2-3	2-5	2-5	2-7.5	5.5-10
	Standard	Hp.	2	3	3	5	7.5	7.5
	Speed	rpm	1,400	1,400	1,430	1,440	1,450	1,450
		V/Ph/Hz	380/3/50	380/3/50	380/3/50	380/3/50	380/3/50	380/3/50
	Starter Type (Field Supplied)		D.O.L. Only				D.O.L. or Star-Delta	
Insulation PE. Foam	Thermal Coefficient		0.036 W/m deg K					
	Thickness	in. (mm.)	0.4 (10)					
Air Filters	Factory Supplied							
	No...Size	in.	1...16x20x1	3...16x25x1	3...16x25x1	3...16x25x1	8...20x20x2	6...20x25x2
			1...16x25x1	3...10x20x1	3...20x25x1	3...20x25x1	-	2...16x20x2
Connection	Suction Pipe	in.	2x1 1/8	2x1 1/8	2x1 3/8	2x1 3/8	2x1 3/8	2x1 3/8
	Discharge Pipe	in.	2x1/2	2x1/2	2x5/8	2x5/8	2x5/8	2x7/8
Condensate Pipe		in.	3/4	3/4	1	1	1 1/4	1 1/4
Subbase	Field Supplied				Factory Supplied			

Coil connection

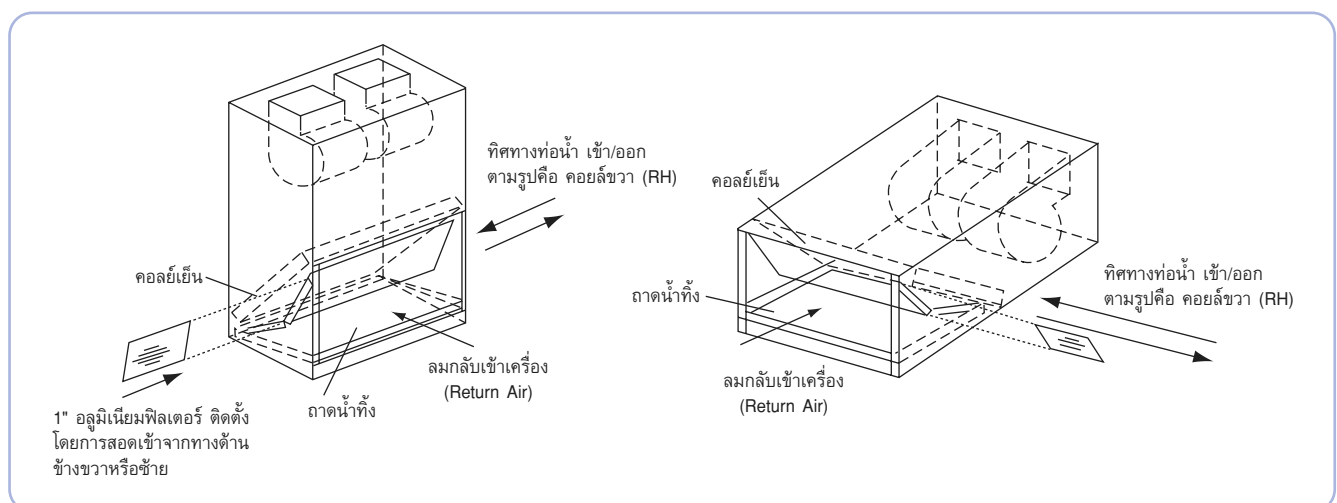

Unit dimensions

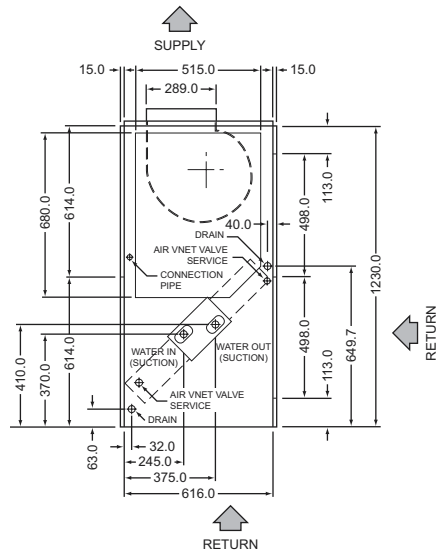
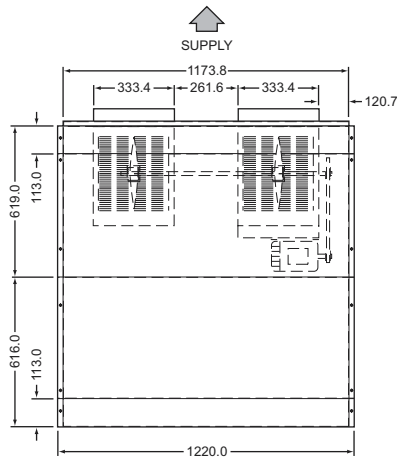

Model : 40RR010 Vertical & Horizontal Type

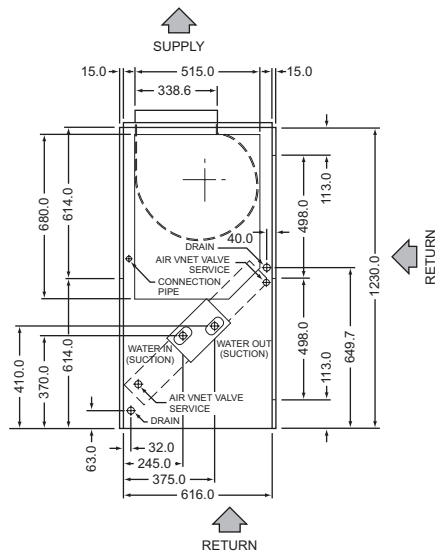
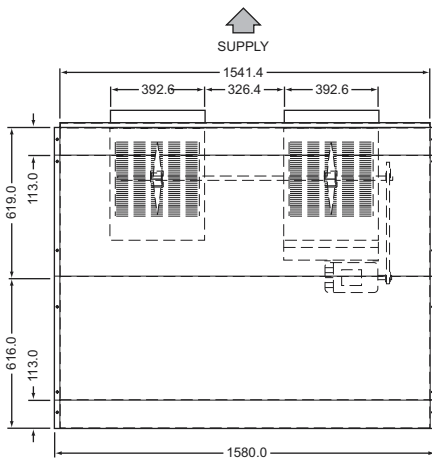

Model : 40RR015 Vertical & Horizontal Type

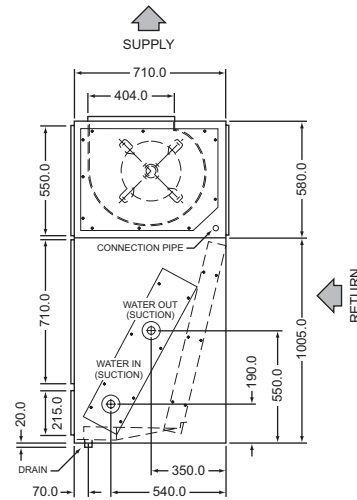
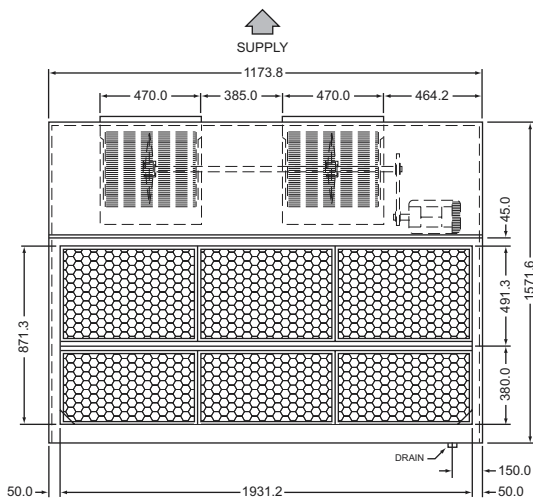

Model : 40RR020, 025 Vertical Type

Unit dimensions

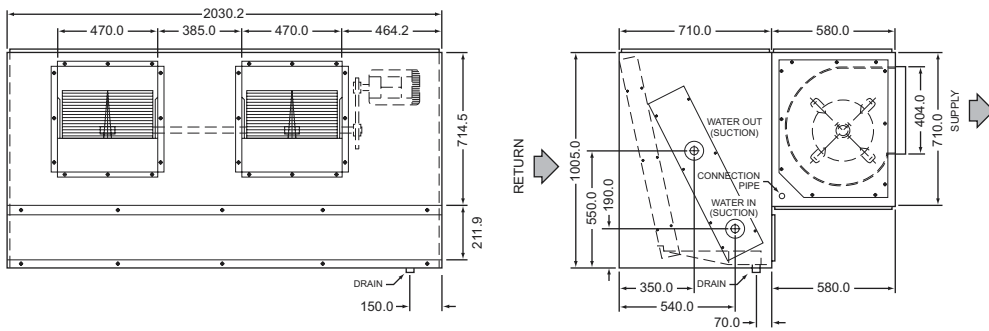

Model : 40RR020, 025 Horizontal Type

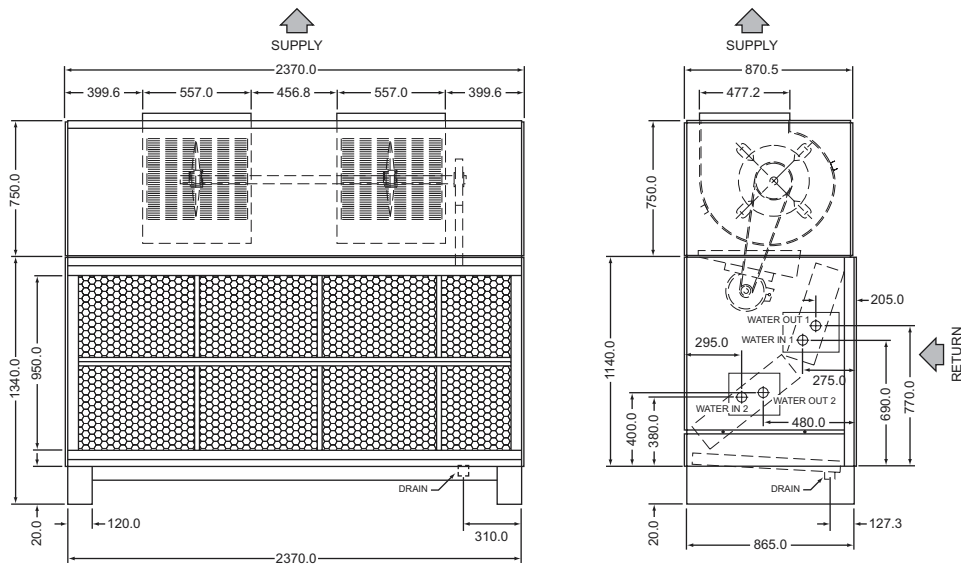

Model : 40RR030, 040 Vertical Type

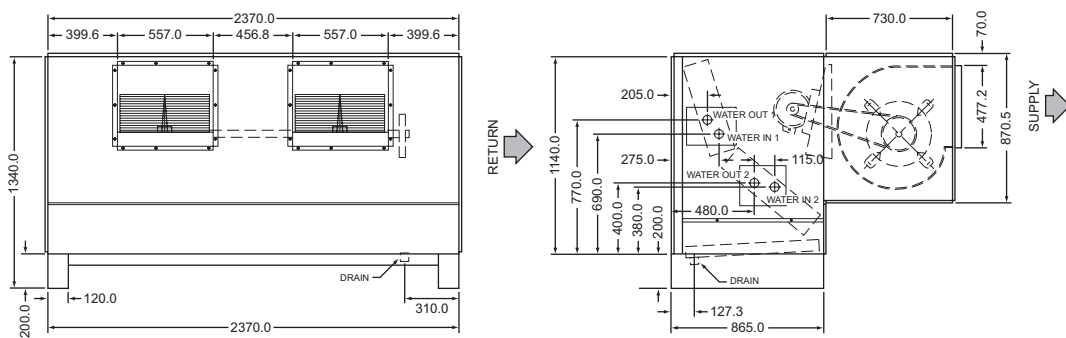

Model : 40RR030, 040 Horizontal Type

Matching capacity

Model 38AE010/40RR010

Ambient Temp. (°F)		Air Volume (CFM)								
		2,000			2,700			3,000		
		EVAP. Air (Ewb)			EVAP. Air (Ewb)			EVAP. Air (Ewb)		
		62	67	72	62	67	72	62	67	72
90	TC	98.1	108.5	119.4	104.5	115.3	126.9	110.5	124.5	134.1
	KW	8.3	8.6	8.9	8.5	8.8	9.2	8.6	9.1	9.3
	SST	33.3	38.1	42.9	36.4	41.2	46.0	39.1	45.1	48.9
95	TC	95.8	106.1	116.9	102.1	112.8	124.2	108.0	121.4	131.1
	KW	8.6	8.9	9.3	8.8	9.1	9.5	9.0	9.4	9.8
	SST	34.0	38.9	43.6	37.0	41.8	46.7	39.7	45.5	49.5
100	TC	93.7	103.8	114.4	99.8	110.2	121.4	105.4	118.3	128.5
	KW	8.9	9.3	9.7	9.1	9.5	10.0	9.3	9.9	10.3
	SST	34.7	39.6	44.4	37.7	42.5	47.3	40.3	46.0	50.2
Nominal		120,000 BTU/Hr AT 3,300 CFM, SST=45.0°F, AMT=95°F, Ewb=67°F								

Model 38AE015/40RR015

Ambient Temp. (°F)		Air Volume (CFM)								
		3,200			4,300			5,400		
		EVAP. Air (Ewb)			EVAP. Air (Ewb)			EVAP. Air (Ewb)		
		62	67	72	62	67	72	62	67	72
90	TC	127.4	140.2	154.0	136.7	150.4	164.9	144.1	158.0	173.1
	KW	12.3	12.9	13.5	12.7	13.4	14.0	13.1	13.7	14.3
	SST	33.1	37.8	42.6	36.5	41.4	46.2	39.2	44.0	48.8
95	TC	124.8	137.3	150.8	133.6	147.1	161.3	140.8	154.5	165.7
	KW	12.8	13.4	14.1	13.2	13.9	14.6	13.6	14.2	15.6
	SST	33.8	38.5	43.3	37.1	42.0	46.8	40.4	45.2	50.7
100	TC	122.1	134.3	147.7	130.4	143.8	157.7	137.5	151.0	158.3
	KW	13.2	14.0	14.7	13.7	14.5	15.2	14.2	14.7	16.9
	SST	34.5	39.6	44.0	38.9	43.3	47.4	41.0	45.9	52.6
Nominal		150,000 BTU/Hr AT 5,300 CFM, SST=45.0°F, AMT=95°F, Ewb=67°F								

Model 38AE020/40RR020

Ambient Temp. (°F)		Air Volume (CFM)								
		4,400			5,900			7,400		
		EVAP. Air (Ewb)			EVAP. Air (Ewb)			EVAP. Air (Ewb)		
		62	67	72	62	67	72	62	67	72
90	TC	168.7	186.2	205.1	180.3	198.6	218.1	189.4	208.2	231.1
	KW	15.9	16.7	17.5	16.4	17.2	18.0	16.8	17.6	18.5
	SST	35.4	40.1	44.8	38.5	43.2	48.0	40.9	45.6	51.2
95	TC	164.5	181.6	200.1	175.6	193.6	212.8	184.3	202.8	225.5
	KW	16.4	17.2	18.1	16.9	17.8	18.8	17.4	18.3	19.5
	SST	36.1	40.8	45.5	39.2	43.8	48.6	41.5	46.1	51.7
100	TC	160.2	176.9	195.2	170.8	188.5	207.5	179.3	197.5	219.8
	KW	16.9	17.9	18.8	17.6	18.5	19.5	18.0	19.0	20.2
	SST	36.7	41.4	46.1	39.8	44.4	49.1	42.0	46.7	52.1
Nominal		200,000 BTU/Hr AT 6,600 CFM, SST=45.0°F, AMT=95°F, Ewb=67°F								

Model 38AE025/40RR025

Ambient Temp. (°F)		Air Volume (CFM)								
		5,200			6,800			8,600		
		EVAP. Air (Ewb)			EVAP. Air (Ewb)			EVAP. Air (Ewb)		
		62	67	72	62	67	72	62	67	72
90	TC	250.3	276.3	304.4	256.9	283.4	312.3	267.5	295.1	320.2
	KW	21.6	22.6	23.6	21.8	22.9	22.3	23.9	23.3	24.2
	SST	38.0	42.8	47.6	39.3	44.1	48.9	41.2	46.2	50.2
95	TC	244.0	269.5	297.0	250.3	276.3	304.5	260.6	287.5	312.0
	KW	22.4	23.4	24.5	22.7	23.7	24.8	23.1	24.1	25.1
	SST	38.6	43.4	48.2	39.8	44.6	49.5	41.7	46.6	50.8
100	TC	237.7	262.6	289.5	243.7	269.1	296.7	253.5	279.7	303.9
	KW	23.1	24.3	25.5	23.4	24.6	25.7	23.9	25.1	25.9
	SST	39.2	44.0	48.8	40.4	45.2	50.1	42.2	47.1	51.4
Nominal		280,000 BTU/Hr AT 8,000 CFM, SST=45.0°F, AMT=95°F, Ewb=67°F								

Model 38AE030/40RR030

Ambient Temp. (°F)		Air Volume (CFM)								
		6,500			8,600			10,700		
		EVAP. Air (Ewb)			EVAP. Air (Ewb)			EVAP. Air (Ewb)		
		62	67	72	62	67	72	62	67	72
90	TC	271.3	275.9	291.9	288.5	318.0	349.4	301.7	332.1	406.9
	KW	23.5	23.7	24.3	24.2	25.2	26.2	24.6	25.7	28.1
	SST	36.3	37.1	39.9	39.3	44.2	49.1	41.5	46.4	58.3
95	TC	265.1	269.8	286.2	281.8	310.8	341.8	294.6	324.4	397.4
	KW	24.4	24.6	25.2	25.1	26.1	27.3	25.5	26.6	29.4
	SST	36.9	37.7	40.6	39.9	44.7	49.6	42.0	46.9	58.6
100	TC	258.9	263.8	280.5	275.1	303.6	334.2	287.5	316.6	387.9
	KW	25.1	25.3	26.0	25.8	27.1	28.4	26.3	27.6	30.8
	SST	37.5	38.4	41.3	40.4	45.2	50.1	42.5	47.3	58.9
Nominal		310,000 BTU/Hr AT 8,600 CFM, SST=44.7°F, AMT=95°F, Ewb=67°F								

Model 38AE040/40RR040

Ambient Temp. (°F)		Air Volume (CFM)								
		7,800			10,300			13,000		
		EVAP. Air (Ewb)			EVAP. Air (Ewb)			EVAP. Air (Ewb)		
		62	67	72	62	67	72	62	67	72
90	TC	335.9	370.1	406.0	361.0	396.6	434.7	380.7	417.6	463.4
	KW	33.5	35.4	37.3	34.9	36.8	38.7	36.0	37.9	40.1
	SST	35.6	40.5	45.4	39.2	44.2	49.1	42.0	46.9	52.8
95	TC	328.9	362.4	397.6	353.1	388.0	425.2	371.9	408.0	452.8
	KW	34.5	36.5	38.5	35.9	38.0	40.1	37.0	39.1	41.7
	SST	36.2	41.1	46.0	39.8	44.7	49.6	42.4	47.4	53.2
100	TC	321.3	353.8	388.9	344.0	379.0	415.7	362.5	398.3	442.5
	KW	35.6	37.8	39.9	37.2	39.3	41.5	38.3	40.5	43.1
	SST	36.8	41.7	46.6	40.4	45.2	50.1	42.9	47.8	53.6
Nominal		388,000 BTU/Hr AT 10,300 CFM, SST=45.0°F, AMT=95°F, Ewb=67°F								

Remark: TC - TOTAL CAPACITY (1,000 BTU/Hr)
 KW - KILOWATT INPUT OF COMPRESSOR
 SST - SATURATED SUCTION TEMPERATURE (°F)
 AMT - AMBIENT TEMPERATURE (°F)

Assume: - 10°F SUCTION SUPERHEAT
 - 15°F SUBCOOLING
 - PERFORMANCE DATA IS WITH R-22
 - SHADE AREAS INDICATE UNRECOMMENDED ST OR CDT.

Matching capacity

Model 38LB012/40RR010

Ambient Temp. (°F)		Air Volume (CFM)								
		2,000			2,700			3,000		
		EVAP. Air (Ewb)			EVAP. Air (Ewb)			EVAP. Air (Ewb)		
		62	67	72	62	67	72	62	67	72
90	TC	100.4	111.0	121.6	107.2	118.2	128.3	113.5	125.8	135.1
	KW	10.6	11.2	11.9	11.0	11.7	12.3	11.4	12.2	12.8
	SST	32.0	36.6	41.6	35.0	39.8	45.1	37.8	43.8	48.1
95	TC	95.2	106.2	118.0	102.1	113.5	126.3	108.4	123.5	133.9
	KW	11.0	11.6	12.3	11.4	12.0	12.7	11.8	12.5	13.1
	SST	33.6	38.2	42.6	36.5	41.0	46.1	39.1	44.6	48.3
100	TC	94.3	105.4	115.9	101.2	112.1	122.6	107.6	120.2	129.1
	KW	11.2	12.6	12.6	11.6	12.3	13.1	12.0	13.0	13.6
	SST	33.9	38.4	43.3	36.7	41.4	46.5	39.3	45.4	49.4

Nominal 123,000 BTU/Hr AT 3,400 CFM, SST=44.6°F, AMT=95°F, Ewb=67°F

Model 2x38LB060/40RR010

Ambient Temp. (°F)		Air Volume (CFM)								
		2,000			2,700			3,400		
		EVAP. Air (Ewb)			EVAP. Air (Ewb)			EVAP. Air (Ewb)		
		62	67	72	62	67	72	62	67	72
90	TC	100.8	110.8	121.2	107.3	117.5	128.5	113.2	125.8	136.7
	KW	10.6	11.7	12.7	11.3	12.4	13.2	11.9	13.0	13.4
	SST	31.8	36.7	41.7	35.0	40.0	45.1	37.9	43.8	47.7
95	TC	97.9	107.7	117.9	104.1	114.2	125.7	109.8	122.7	135.0
	KW	10.9	12.0	12.9	11.6	12.6	13.3	12.2	13.3	13.5
	SST	32.8	37.7	42.7	35.9	40.8	45.7	38.7	44.9	48.1
100	TC	97.2	107.1	117.4	103.5	113.5	124.8	109.1	122.2	132.8
	KW	11.0	12.1	13.1	11.7	12.8	13.5	12.3	13.4	13.8
	SST	33.0	37.9	42.8	36.1	41.0	45.9	38.9	45.1	48.6

Nominal 122,700 BTU/Hr AT 3,400 CFM, SST=44.9°F, AMT=95°F, Ewb=67°F

Model 2x38LB007/40RR015

Ambient Temp. (°F)		Air Volume (CFM)								
		3,200			4,300			5,400		
		EVAP. Air (Ewb)			EVAP. Air (Ewb)			EVAP. Air (Ewb)		
		62	67	72	62	67	72	62	67	72
90	TC	129.4	142.2	155.8	138.9	152.3	166.4	146.2	159.8	174.4
	KW	13.1	13.7	14.3	13.5	14.1	14.8	13.9	14.5	15.3
	SST	32.6	37.3	42.2	36.1	41.0	45.9	38.8	43.6	48.6
95	TC	126.5	139.0	152.3	135.5	148.7	162.5	142.6	155.9	166.2
	KW	13.6	14.2	14.9	14.0	14.7	15.5	14.3	15.1	16.5
	SST	33.4	38.1	43.0	36.8	41.7	46.6	39.5	44.3	49.9
100	TC	125.2	137.5	150.6	133.9	147.0	158.6	140.9	152.0	158.0
	KW	13.7	14.4	15.1	14.2	14.9	16.0	14.6	15.7	17.7
	SST	33.7	38.5	43.4	37.1	42.0	47.3	39.8	45.0	52.2

Nominal 155,900 BTU/Hr AT 5,400 CFM, SST=43.3°F, AMT=95°F, Ewb=67°F

Model 2x38LB009/40RR020

Ambient Temp. (°F)		Air Volume (CFM)								
		4,400			5,900			7,400		
		EVAP. Air (Ewb)			EVAP. Air (Ewb)			EVAP. Air (Ewb)		
		62	67	72	62	67	72	62	67	72
90	TC	170.8	188.4	207.2	182.6	200.9	220.4	191.8	210.5	-
	KW	17.5	18.6	19.7	18.0	18.6	20.3	18.8	19.9	-
	SST	35.1	39.8	44.5	35.9	40.6	45.3	40.6	45.4	-
95	TC	165.6	183.0	201.3	177.0	194.9	213.8	185.8	204.1	-
	KW	18.0	19.1	20.3	18.0	19.1	20.3	19.3	20.4	-
	SST	35.9	40.6	45.3	35.9	40.6	45.3	41.3	46.0	-
100	TC	163.1	180.2	198.4	174.2	191.9	210.7	182.8	200.9	-
	KW	18.2	19.3	20.5	18.2	19.3	20.5	19.5	20.6	-
	SST	36.3	40.9	45.7	36.3	40.9	45.7	41.6	46.3	-

Nominal 204,100 BTU/Hr AT 7,400 CFM, SST=46.0°F, AMT=95°F, Ewb=67°F

Model 2x38LB012/40RR025

Ambient Temp. (°F)		Air Volume (CFM)								
		5,200			6,800			8,600		
		EVAP. Air (Ewb)			EVAP. Air (Ewb)			EVAP. Air (Ewb)		
		62	67	72	62	67	72	62	67	72
90	TC	223.2	244.6	265.7	234.8	254.7	277.9	247.4	269.0	290.1
	KW	22.5	23.9	25.3	23.2	24.5	26.1	24.0	25.5	26.9
	SST	36.9	41.9	47.1	39.4	44.6	49.7	42.7	47.8	52.3
95	TC	212.1	236.5	262.6	223.7	249.6	276.3	239.5	266.0	290.0
	KW	23.3	24.6	26.0	23.9	25.2	26.8	24.7	26.2	27.6
	SST	38.1	42.7	47.4	40.4	45.1	49.8	43.3	48.0	52.2
100	TC	210.3	231.7	253.2	221.4	241.8	274.7	233.6	255.2	296.2
	KW	23.7	26.6	26.8	24.4	26.0	27.5	25.4	27.0	28.2
	SST	38.3	43.2	49.4	40.6	46.7	49.9	43.7	48.7	50.4

Nominal 248,000 BTU/Hr AT 6,750 CFM, SST=45.0°F, AMT=95°F, Ewb=67°F

Remark: TC - TOTAL CAPACITY (1,000 BTU/Hr)
 KW - KILOWATT INPUT OF COMPRESSOR
 SST - SATURATED SUCTION TEMPERATURE (°F)
 AMT - AMBIENT TEMPERATURE (°F)

Assume: - 10°F SUCTION SUPERHEAT
 - 15°F SUBCOOLING
 - PERFORMANCE DATA IS WITH R-22
 - SHADE AREAS INDICATE UNRECOMMENDED ST OR CDT.

Fan performance data

Unit Model	APD.	CFM	Total Static Pressure (in. wg)																	
			0.4		0.6		0.8		1.0		1.2		1.4		1.6		1.8		2.0	
			RPM	KW	RPM	KW	RPM	KW	RPM	KW	RPM	KW	RPM	KW	RPM	KW	RPM	KW	RPM	KW
40RR010	0.18	2000	592	0.19	747	0.29	-	-	-	-	-	-	-	-	-	-	-	-	-	-
	0.23	2350	599	0.23	726	0.32	859	0.44	-	-	-	-	-	-	-	-	-	-	-	-
	0.28	2700	608	0.29	730	0.39	838	0.49	954	0.62	-	-	-	-	-	-	-	-	-	-
	0.33	3050	623	0.36	736	0.47	841	0.58	937	0.69	1039	0.82	-	-	-	-	-	-	-	-
	0.39	3400	643	0.45	748	0.57	848	0.68	940	0.80	1025	0.94	1116	1.06	-	-	-	-	-	-
40RR015	0.18	3200	516	0.31	651	0.46	-	-	-	-	-	-	-	-	-	-	-	-	-	-
	0.23	3750	522	0.39	631	0.54	747	0.72	-	-	-	-	-	-	-	-	-	-	-	-
	0.28	4300	528	0.49	637	0.66	728	0.82	828	1.02	-	-	-	-	-	-	-	-	-	-
	0.33	4850	539	0.62	641	0.79	734	0.98	814	1.16	900	1.37	997	1.64	-	-	-	-	-	-
	0.39	5400	557	0.77	649	0.95	739	1.15	821	1.35	892	1.56	967	1.79	1050	2.05	-	-	-	-
40RR020	0.17	4400	448	0.40	551	0.59	-	-	-	-	-	-	-	-	-	-	-	-	-	-
	0.22	5150	451	0.51	549	0.70	636	0.92	720	1.16	-	-	-	-	-	-	-	-	-	-
	0.27	5900	455	0.64	549	0.85	634	1.07	709	1.32	784	1.57	-	-	-	-	-	-	-	-
	0.33	6650	465	0.80	554	1.03	634	1.26	708	1.50	776	1.79	842	2.07	908	2.38	-	-	-	-
	0.39	7400	498	1.06	558	1.23	639	1.49	708	1.74	776	2.02	838	2.33	989	2.64	957	2.96	1016	3.31
40RR025	0.23	5200	451	0.52	549	0.71	635	0.93	719	1.16	-	-	-	-	-	-	-	-	-	-
	0.30	6000	455	0.66	550	0.87	634	1.09	709	1.34	782	1.60	-	-	-	-	-	-	-	-
	0.36	6800	470	0.84	555	1.07	634	1.30	708	1.55	776	1.83	841	2.12	905	2.42	-	-	-	-
	0.44	7700	513	1.18	559	1.31	640	1.59	710	1.86	776	2.12	838	2.43	896	2.76	954	3.08	1010	3.42
	0.52	8600	559	1.60	588	1.68	645	1.92	715	2.22	779	2.52	838	2.81	896	3.13	950	3.49	-	-
40RR030	0.23	6500	374	0.59	461	0.86	-	-	-	-	-	-	-	-	-	-	-	-	-	-
	0.30	7550	380	0.77	458	1.04	528	1.35	-	-	-	-	-	-	-	-	-	-	-	-
	0.36	8600	386	0.93	461	1.21	527	1.52	591	1.88	-	-	-	-	-	-	-	-	-	-
	0.44	9650	398	1.17	466	1.47	532	1.79	589	2.13	645	2.52	711	2.99	-	-	-	-	-	-
	0.52	10700	419	1.48	474	1.76	536	2.10	594	2.47	646	2.85	696	3.27	751	3.75	814	4.31	-	-
40RR040	0.23	7800	380	0.78	458	1.05	527	1.36	-	-	-	-	-	-	-	-	-	-	-	-
	0.30	9050	390	1.02	463	1.31	529	1.63	588	1.97	655	2.39	-	-	-	-	-	-	-	-
	0.36	10300	410	1.35	471	1.65	534	1.98	592	2.34	644	2.71	698	3.14	761	3.65	-	-	-	-
	0.44	11650	440	1.82	485	2.08	542	2.45	597	2.81	650	3.22	698	3.63	744	4.08	792	4.57	847	5.14
	0.52	13000	470	2.39	510	2.67	554	2.98	606	3.41	655	3.81	704	4.26	749	4.71	791	5.18	831	5.68



YOUR CARRIER MAN : Bene Engineering Ltd.,Part.
 137/274 ม.5 แขวงท่าแร้ง เขตบางเขน กรุงเทพฯ 10200
 Tel. 02-9495702-3 Fax. 029451332
www.beneair.com E-mail sales@beneair.com